



# cosmopix<sup>R</sup>

USER MANUAL V.1

ENGLISH VERSION  
09 17 2015



**AYRTON**  
Digital Lighting



## SUMMARY

4	Introduction
4	Safety instructions
4	Conditions of use
5	Presentation and features
6	Dimensions
6	Description
7	Installation instructions
7	Installation method using truss hooks
7	DMX512 connection
8	DMX512 connection with termination plug
8	The CosmoPix R DMX address setting
8	Control Panel
9	CosmoPix R control panel menu - Option details
12	Master/Slave Mode settings
13	Led mapping
14	DMX Chart
16	Error Messages
16	Care and maintenance
17	Technical Specifications
18	Warranty

## INTRODUCTION

Thank you for selecting the AYRTON COSMOPIX-R luminaire.

### WARNING !

*This product is not suitable for household use.*

You now own a professional lighting unit that offers endless possibilities. Before installing, make sure that no damage was done to your luminaire during transport. If this is the case, do not use the product and immediately contact your authorized AYRTON dealer.

For your own safety and that of others, please read this instruction manual carefully before installing the unit.

Anyone involved in installing, operating or servicing the COSMOPIX-R must:

- Be a qualified, authorized professional
- Strictly follow the instructions in this user manual.

Please take the time to read this manual carefully and thoroughly before installing and operating the luminaire. You should have a good knowledge of its operating conditions and all pertinent product information.

After you have become familiar with this manual, we recommend that you keep a copy for future use. All the information found in this manual is subject to change without notice. AYRTON reserves the right to modify and upgrade its range of products, with no obligation to integrate these changes into products already sold.

## SAFETY INSTRUCTIONS

Please read the safety instructions and warnings in this manual carefully before installing and operating the COSMOPIX-R.

### WARNING!

*Risk of electric shock.*

*Use caution when handling. This luminaire requires high voltage, which can result in electric shock.*

The COSMOPIX-R left our factory in perfect working condition. However, if you notice a defect, immediately contact your authorized AYRTON dealer before use. The manufacturer cannot be held responsible for damages caused by a failure to follow the safety, installation or assembly instructions contained herein, or by any modification made to the luminaire.

Failure to observe the safety, installation or assembly instructions contained herein, or any modification made to the COSMOPIX-R luminaire will render the warranty null and void.

Check that the supply voltage does not exceed the maximum authorized limit. Check that your electrical installation complies with current standards.

In all cases, make sure that the power cables attached to your COSMOPIX-R have not been damaged due to cuts and splices or crushed in any way. Handle these cables with extreme caution while they are connected to a power source.

Your COSMOPIX-R conforms to Class 1 safety standards. The unit must be grounded electrically. Make sure that the power source connected to your COSMOPIX-R is switched off before attempting any work on it.

Installation and connection to an electrical source must be performed by an authorized installer. AYRTON declines all responsibility should this luminaire be installed by an unqualified person.

Never disconnect your COSMOPIX-R by pulling on the power cable! First unlock the connector lock ring on the power cable until it is fully disengaged, and then gently pull on the connector to disconnect the cable.

Do not connect or disconnect the power cable of your COSMOPIX-R with wet hands.

At first use, your COSMOPIX-R may give off an odor. This is a normal occurrence that should dissipate after a few minutes of operation.

### WARNING!

*Do not connect or disconnect the power cable at your COSMOPIX-R if the cable is energized! This could cause arcing and damage your COSMOPIX-R, requiring repair.*

Be careful to power off your COSMOPIX-R by removing the power plug from the source, before connecting or disconnecting the luminaire.

### WARNING!

*This unit contains Class 2 LED emitters (EN60625-1): 1994)*

This luminaire uses multiple high-power (Class 2) LED-type (Light Emitting Diode) lamps. Never look directly into the lamps if lit or stand directly in line with the luminaire if close by.

Installation, removal or replacement of the unit must be performed with power off to prevent any risk of glare and eye injury.

### WARNING!

*The fixture quickly becomes very hot during operation.*

To avoid risk of burn, never handle or adjust the luminaire while it is energized and after it has been lit for more than 10 consecutive minutes. Some parts of the luminaire can reach a high temperature, particularly the body/radiator. Turn off the luminaire and wait for it to cool before handling.

## CONDITIONS OF USE

Your COSMOPIX-R is a moving-head luminaire equipped with multiple LEDs intended for professional use (e.g., architectural, stage, television, theater, or museum lighting).

The COSMOPIX-R luminaire has an IP20 protection rating. It is intended strictly for indoor use. It must never be partially or fully submerged, even temporarily.

Condensation may form on your COSMOPIX-R in the following cases:

- Immediately after turning on the heating
- In places with fog or a high level of humidity

- When the luminaire is suddenly moved from a cold to a warm environment, or vice versa.

In such cases, you must wait until the luminaire readjusts to the ambient temperature of the room where it will be installed for operation.

Do not shake the COSMOPIX-R while installing or handling.

Do not pull the COSMOPIX-R by one of its cables to move it. Lift the luminaire by its handles.

Choosing the appropriate place to install the COSMOPIX-R is essential. The following points should be observed:

- Do not expose it to a heat source.
- Do not install it near flammable materials.
- Be sure that dust or miscellaneous debris cannot clump around the body of the luminaire as this may interfere with its optimal cooling and proper operation.
- The COSMOPIX-R must be installed out of reach of the public and all persons not authorized to operate the luminaire.

We recommend a minimum distance of 20 cm between the outside surface of the light and the illuminated object. The color mixture of the COSMOPIX-R can be improved if the illuminated surface is very close to the luminaire (up to about 50 cm).

Due to the nature of its cooling principle, you should never prevent air from circulating around the body of the luminaire. You must provide a minimum clearance of 20 cm around your COSMOPIX-R to allow for cooling.

The COSMOPIX-R can be installed in a ground pit or any other confined enclosure only under certain conditions. With this kind of installation, a system of forced ventilation should be used up to allow air to circulate freely around the luminaire(s). The air must be constantly renewed because the luminaire cannot be operated in closed system. Failure to comply with these requirements may destroy or prematurely wear the COSMOPIX-R, and AYRTON cannot be held responsible. Please consult your AYRTON dealer for more information on this type of installation.

No load should be placed on the COSMOPIX-R. The fixture must not be installed in such a way as to allow a person, vehicle or any object to run over or park on it.

Never lay or drop any hard, heavy, or blunt, objects on the COSMOPIX-R. This includes items made of glass or porcelain (e.g., bottles, dishware, or glass beads). The luminaire is made of materials such as plastic and extruded aluminum, making it resistant but not unbreakable. Objects made of hard materials such as steel or glass that fall on the unit may cause breakage of the plastic parts or the body. AYRTON cannot be held responsible for the luminaire's broken plastic parts or body, which are not covered under warranty.

The temperature of the room where the COSMOPIX-R is installed must never exceed 45°C (Ta = 45°C).

The COSMOPIX-R luminaire requires a 110-240 VAC supply voltage. Check that your luminaires have been installed for an application that is compatible with this information.

Check that the brackets on which you hang or attach your COSMOPIX-R can sustain the weight of the luminaire (25,1 kg), taking into consideration all necessary safety factors.

Do not use your COSMOPIX-R before being familiar with these recommendations and do not allow unqualified personnel to handle the product.

To transport your COSMOPIX-R, we strongly recommend that you use the complete original packaging, including the dense protective foam inserts.

If your COSMOPIX-R is not being used for a long period, you should disconnect the luminaire from the power source.

Never dispose of the COSMOPIX-R in a rubbish bin. Ensure that it is recycled. Please consult the current legislation in your country on recycling electronic equipment.

### **WARNING!**

*The number of daisy chain, or tandem, connections to the COSMOPIX-R (power input and output sockets on the luminaires) is limited for safety reasons. The maximum authorized number of connections is as follows, with the power line protected by a 10A circuit breaker:*

*2 COSMOPIX-R units on the same source at 230 VAC or  
1 COSMOPIX-R units on the same source at 110 VAC.*

## **PRESENTATION AND FEATURES**

COSMOPIX-R is a non-waterproof moving head wash light (IP20 protection rating) using the latest generation of high-performance of LED-type lamps.

This luminaire can be controlled remotely by an external DMX512 signal.

The COSMOPIX-R incorporates multi-chip LEDs using 4 colors: Red, green, blue and white.

This color-light luminaire operates on the CMY additive color principle and along with white light can potentially render a palette of 4.2 billion colors.

The COSMOPIX-R has a total of 12 LEDs that can be controlled independently. The luminaire requires from 18 to 64 DMX channels to be controlled via an external command system that sends a DMX512 signal (see below for details).

To adjust the settings on the COSMOPIX-R (i.e., DMX address, DMX operating mode and other options), a Remote Device Management (RDM)-type DMX controller may be required. The DMX RDM protocol is a universal, widely used standard.

There are a multitude of RDM DMX controllers on the market from different manufacturers (excluding AYRTON). It is worth noting that an RDM DMX controller is not required to change the settings on the COSMOPIX-R. A light console or any standard DMX-type controller is sufficient.

The COSMOPIX-R consists of a metal frame and plastic covers. The power connectors and DMX512 signal connectors are on the back of the fixture's base.

## DIMENSIONS

Bottom view

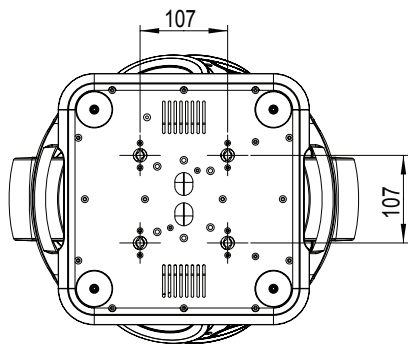

Front view

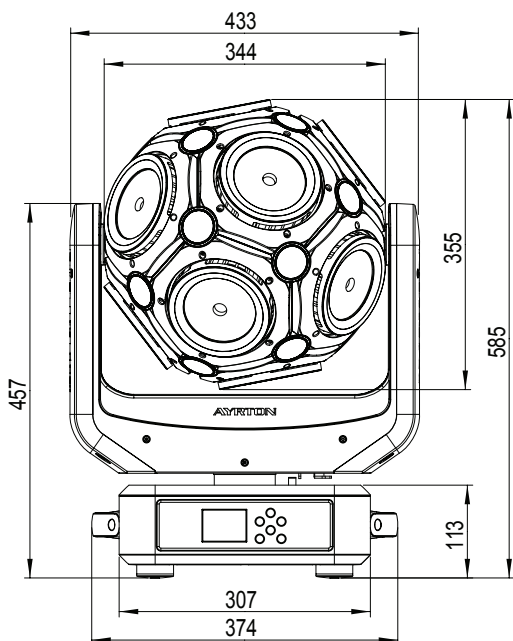

Side view

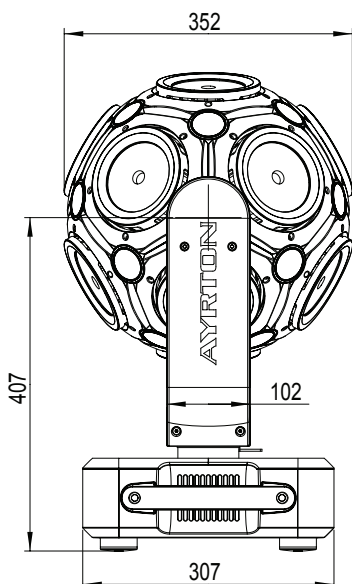

## DESCRIPTION

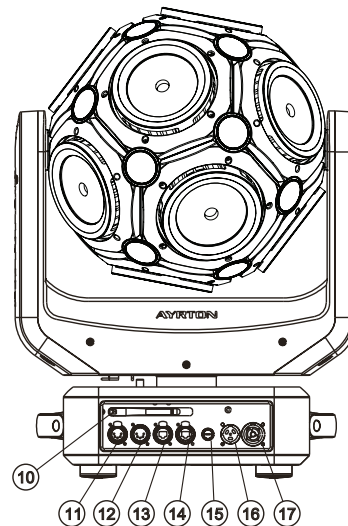
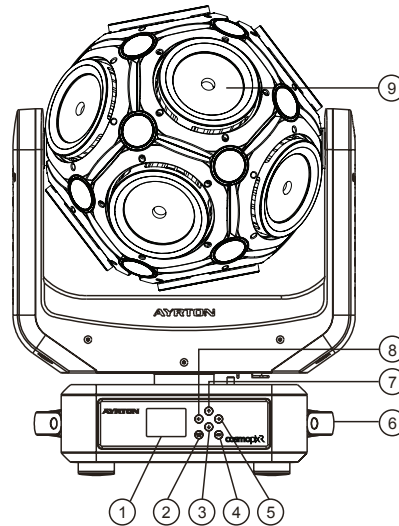

1. LCD Display
2. MODE/ESC button
3. Down button
4. Enter button
5. Right button
6. Handle
7. Up button
8. Left button
9. LED Assembly
10. Antenna – Wireless DMX
11. DMX512 output connector (5-pin)
12. DMX512 input connector (5-pin)
13. RJ45 output connector
14. RJ45 input connector
15. Fuse holder
16. Power source input connector
17. Power source output connector

## INSTALLATION INSTRUCTIONS

*During installation please observe the instructions according to GB7000.15 / EN60598-2-17 standards and other national standards applicable. This luminaire should be installed by a qualified technician.*

The fixture should be used in an environment with a temperature between -5°C and +45°C. Do not operate the luminaire outside this temperature range.

The luminaire must be hung so that the weight of this unit multiplied by 10 can be sustained for 1 hour without causing the suspension system or the supporting structure to be deformed.

The installation must always be secured at a second attach point, e.g., by a safety cable of the appropriate size.

Do not stand under the luminaire while it is being installed, dismantled or serviced.

The operator must ensure that a qualified technician has approved the installation of the luminaire for safety before it is first operated.

Installation should be inspected once a year by a qualified technician.

### WARNING!

*The installation of this luminaire must be validated by a qualified technician before it is used for the first time.*

The luminaire should be installed in a location where the public cannot touch, walk or sit on the luminaire.

Suspending the luminaire and/or installing it high up requires considerable experience, e.g., calculating load, selecting and adapting quality fastening materials, and periodically inspecting the entire installation. Without this skill and knowledge, do not attempt to install this unit by yourself. Improper installation may cause an accident resulting in personal injury or death.

### WARNING!

*The luminaire should be connected to an electrical source by a qualified electrician.*

Before installing the luminaire make sure that the selected installation spot can support at least 10 times the weight of the unit. Connect the luminaire to the power source by the power cord.

## INSTALLATION METHOD USING TRUSS HOOKS

Refer to the following diagram when installing the COSMOPIX-R with truss hooks using omega bracket:

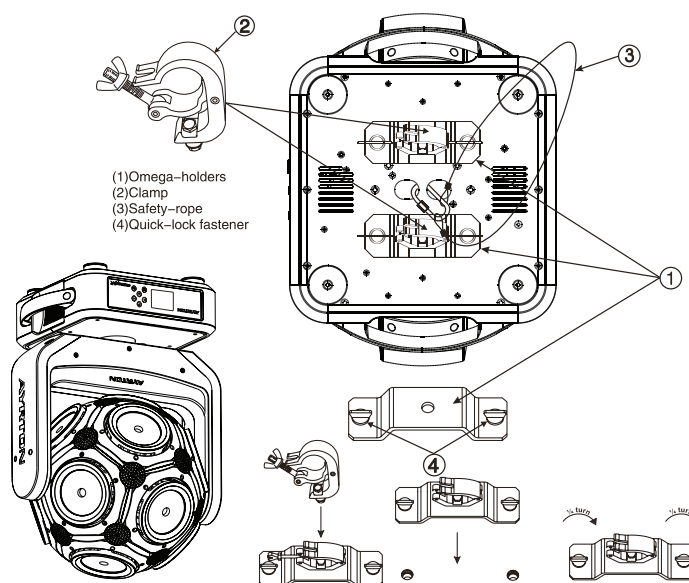

- Attach the clamp to the omega bracket using an M12 screw.
- Insert the quick-lock fasteners of the first omega bracket into the respective holes on the base of the unit. Turn the quick fasteners fully clockwise.
- Install the second omega bracket.
- Insert the safety cable through the holes at the bottom of the base and the truss or a stable attachment point. Insert the end into the hole and tighten the safety screw.

Note: The last step is very important to ensure that the luminaire does not fall..

## DMX512 CONNECTION

Connect the DMX input (XLR connector) cable of the luminaire to the DMX output (female XLR connector) of your controller. You can connect multiple luminaires to this same DMX line in a daisy chain. The DMX cable must be a shielded twisted pair that is equipped with male and female XLR connectors.

Refer to the following diagram when connecting the COSMOPIX-R luminaires in a daisy chain:

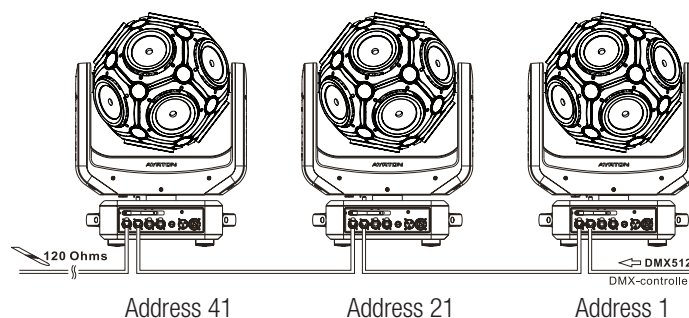

## DMX512 CONNECTION WITH TERMINATION PLUG

For installations where the DMX cable must extend over long distances, or if it is located near areas with major electrical disturbance, it is recommended to use a DMX termination plug. This helps prevent luminaires from malfunctioning due to interference. The DMX termination plug, composed simply of a male XLR input connector with a 120-Ohm resistor, is soldered between pins 2 and 3. This plug must be connected to the DMX output of the last luminaire in the chain.

Refer to the following diagram:

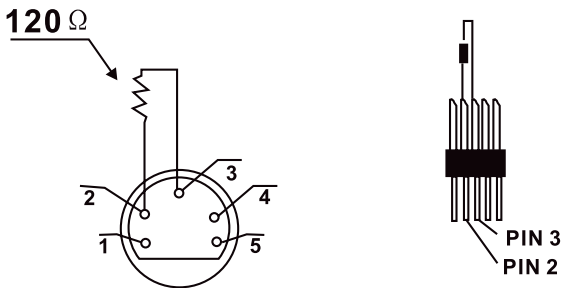

## USING DMX VIA ART-NET

To control the COSMOPIX-R via ART-NET, the fixtures must be interconnected with CAT5 RJ45 cable. Be careful to enter all necessary information into the ART-NET universe being used and specify in the menu that the COSMOPIX-R is being controlled through ART-NET (see OPTION DETAILS in the « OPTIONS » menu).

### WARNING!

*The COSMOPIX-R can only read the first twenty four universes of an ART-NET package. If you have more than 24 universes in your network, you must use a configurable switch to filter each RJ45 output.*

## THE COSMOPIX-R DMX ADDRESS SETTING

All luminaires have a DMX start address correctly set when using a DMX signal to control them. The DMX start address is the channel from which the luminaire “listens” to the digital control information sent by the DMX controller.

The start address must conform to the one recorded on the DMX controller to run the luminaire. This address is the DMX value that appears on the luminaire’s display. You can set the same address for all the luminaires, or some of them, but you can also set a different address for each luminaire, as needed.

If you do set the same address for all the luminaires, they will all “listen” from the DMX channel you have set. The instructions sent by the DMX controller will affect all luminaires at the same time. If you set a different address per luminaire, the DMX controller can control each independently.

If, for instance, the fixtures are preset in 64 -channel DMX mode (required for full control), you will need to adjust the DMX address for the luminaires as follows: The first unit with DMX address 001, the second with DMX address 065 (64 + 1), the third with DMX address 129 (65 + 64), etc.

## CONTROL PANEL (MENU OPTIONS)

A large number of settings are accessible from the fixture’s control panel. A good working knowledge of it will enhance the fixture’s possibilities.

You can access the Main Menu by pressing the **mode esc** key until the display flashes.

Cycling through the menus is performed by pressing the **▲**, **▼**, **◀** or **▶** keys, as required:

Press the **enter** key to select the desired menu.

Change the selection by pressing the **▲**, **▼** or **◀**, **▶** keys.

Confirm your selection by pressing the **enter** key.

Exit a menu at any time by pressing the **mode esc** key.

Notes:

You can return to the display by pressing the **◀** or **▶** keys from the basic display.

If the screen fails to respond, hold the “Mode Esc” key down for at least 3 seconds to free up the display.

The fixture’s menu functions are described in the following table:

Address	Set Dmx Addr	A001~AXXX	DMX address setting	
Users Mode	User Mode	Stand Mode Basic Mode Extend Mode User Mode A User Mode B User Mode C	User’s mode to change channel numbers	
	Edit User	Max channel PAN :	Edit DMX profile	
Options	Status	No DMX Mode Pan Reverse Tilt Reverse Pan Degree Tilt Degree Feedback Pan/Tilt Spd Hibernation	Close/Hold/Auto/Music ON/OFF ON/OFF 630/540 270/540 ON/OFF Speed 1 ~ 4 OFF, 01min > 99min	
	Service PIN	Service PIN RDM PID Set IP Set Device ID	Password=XXX xxxxxx xxx.xxx.xxx.xxx xx	
	Fans Control	Head Control	Auto Stage Studio	Head Fans Speed Mode Select
	Disp.Setting	Shutoff Time Flip Display Key Lock DispFlash	02~60m 05m ON/OFF ON/OFF ON/OFF	Display shutoff time Reverse 180 degree Key Lock No Signal Flash
	Signal Select	DMX WDMX ArtNet sACN		DMX Wireless DMX Art-Net sACN
	Set Universe	xx		Art-Net Universe NO.
	Temp. C/F	Celsius Fahrenheit		Temperature switch between °C/°F
	Initial Pos.	PAN =XXX		Initial effect position
	Wireless DMX	Activate WDMX Act&Data Out Rest WDMX		AActivate WDMX Activate & Data Out Reset Wireless DMX Mem
	Trigger	DMX Value Disp. Set To Slave Auto Program	PAN, TILT etc. Slave1, Slave2, Slave3 Master / Alone	DMX value display Slave setting Auto program
Reset Default	ON/OFF		Restore factory sett.	



Info	Time Info.	Current Time Til Life Hrs Last Run Hrs Timer PIN Clr Last Run	XXXX(Hours) XXXX(Hours) XXXX(Hours) Password=XXX ON/OFF	
	Temp. Info	Head Temp.	XXX °C/°F	
	Software Ver	V1.2...	Software version	
	Network	IP,Mask,Mac	Network setting	
Test	Home	All Pan&Tilt	Reset all motors Reset Pan&Tilt	
	Test Channel	PAN . . . . .	Test function	
	Manual Ctrl.	PAN =XXX :	Fine adjustment of parameters	
	Calibration	--Password-- PAN :	Password "050" Calbrate and adjust the effects to standard/right position	
Preset	Select Prog.	Prog. Part 1 = Program 1 ~ 10 Program 1 Prog. Part 2 = Program 1 ~ 10 Program 2 Prog. Part 3 = Program 1 ~ 10 Program 3	Select programs to be run	
	Edit Prog.	Program 1 : Program 10	Testing program Program in loop Save and exit	
	Edit Scenes	Edit Scene 001 ~ Edit Scene 250	Pan,Tilt, . . . . . --Fade Time-- --Secne Time-- Input By Outside	Save and automatically return manual scenes edit
	Scenes Input	XX~XX	Automat. scenes rec	

## COSMOPIX-R CONTROL PANEL MENU – OPTION DETAILS

The following section provides details on the options that can be selected through the control panel menu. Refer to the table above.

Note: You can exit this menu at any time by pressing “Mode Esc” repeatedly until you return to the home screen.

### ADDRESS

Allows you to change a DMX address from the fixture’s control panel.

- ◆ Access the menu by pressing the “Mode Esc” key.
- ◆ Go to the “ADDRESS” menu and press “Enter”, then find “Set DMX Address.”
- ◆ Use the up/down arrows to scroll through until you locate the desired address and press “Enter” to confirm.

### MODE

#### USERS MODE

Allows you to select the DMX mode from the following: “Basic Mode” (18 DMX channels ), “Standard Mode” (20 DMX channels), “Extended Mode” (64 DMX channels), “User Mode A”, “User Mode B”, “User Mode C.”

- ◆ Access the menu by pressing the “Mode Esc” key.
- ◆ Use the up/down arrow keys to reach the “MODE” menu and press “Enter.” Then from “User Mode” choose one of the 6 modes above. Consult the “CHART DMX” table for more information on Basic, Standard and Extended Mode. “User Modes A”, “B”, or “C” are user-definable

#### EDIT USER A, B, C

To customize the mode, go to “MODE” and select “Edit UserMode A, B or C” and press “Enter.” Scroll through each setting and press “Enter” to set the desired address.

## OPTIONS

### STATUS

#### No DMX Mode

Defines the fixture’s state when there is no command signal from the DMX controller. The fixture can either launch a program automatically, close the shutter, or even remain in the state when the last DMX values (Hold) were received. The default setting is “Hold.”

- ◆ Access the menu by pressing the “Mode Esc” key.
- ◆ Use the up/down arrow keys to reach the “OPTION” menu and press “Enter.” Then use the left/right arrow keys to select “Status.” Finally, use the left/right arrow keys to select “No DMX Mode.”
- ◆ Scroll through the different options using the left/right arrows and press “Enter” to confirm

#### Pan Reverse

Reverses the PAN movement.

- ◆ Access the menu by pressing the “Mode Esc” key.
- ◆ Use the up/down arrow keys to reach the “OPTION” menu and press “Enter.” Then use the left/right arrow keys to select “Status.” Finally, use the left/right arrow keys to select “Pan Reverse.”
- ◆ Scroll through the different options using the left/right arrows and press “Enter” to confirm.

#### Tilt Reverse

Reverses the direction of the TILT movement.

- ◆ Access the menu by pressing the “Mode Esc” key.
- ◆ Use the up/down arrow keys to reach the “OPTION” menu and press “Enter.” Then use the left/right arrow keys to select “Status.” Finally, use the left/right arrow keys to select “Tilt Reverse.”
- ◆ Scroll through the different options using the left/right arrows and press “Enter” to confirm.

#### Pan Degree

Adjusts the amplitude of the PAN movement at 630° or 540°.

- ◆ Access the menu by pressing the “Mode Esc” key.
- ◆ Use the up/down arrow keys to reach the “OPTION” menu and press “Enter.” Then use the left/right arrow keys to select “Status.” Finally, use the left/right arrow keys to select “Pan Degree.”
- ◆ Scroll through the different options using the left/right arrows and press “Enter” to confirm.

#### Tilt Degree

Adjusts the amplitude of the TILT movement at 540° or 270°.

- ◆ Use the up/down arrow keys to reach the “OPTION” menu and press “Enter.” Then use the left/right arrow keys to select “Status.” Finally, use the left/right arrow keys to select “Tilt Degree.”
- ◆ Scroll through the different options using the left/right arrows and press “Enter” to confirm.

#### Feedback

Readjusts the PAN and TILT positions automatically in the event of accidental shifting due to a physical shock.

- ◆ Access the menu by pressing the “Mode Esc” key.
- ◆ Use the up/down arrow keys to reach the “OPTION” menu and press “Enter.” Then use the left/right arrow keys to select “Status.” Finally, use the left/right arrow keys to select “Feedback.”
- ◆ Scroll through the different options using the left/right arrows and press “Enter” to confirm.

**Pan/Tilt Spd**

You can choose between four movement speeds, from “Speed 1” to “Speed 4.” The “Speed 1” setting is the fastest.

- ◆ Access the menu by pressing the “Mode Esc” key.
- ◆ Use the up/down arrow keys to reach the “OPTION” menu and press “Enter.” Then use the left/right arrow keys to select “Status.” Finally, use the left/right arrow keys to select “Pan/Tilt Spd.”
- ◆ Scroll through the different options using the left/right arrows and press “Enter” to confirm.

**Hibernation — Standby mode**

The LEDs and the pan/tilt motors will be powered down if the luminaire receives no DMX signal for 15 minutes (default setting). If the DMX signal is restored after this time limit, the luminaire will perform a RESET before resuming normal operation.

- ◆ Access the menu by pressing the “Mode Esc” key.
- ◆ Use the up/down arrow keys to reach the “OPTION” menu and press “Enter.” Then use the left/right arrow keys to select “Status.” Finally, use the left/right arrow keys to select “Hibernation.”
- ◆ Scroll through the different options using the left/right arrows and press “Enter” to confirm.

**SERVICE PIN**

WARNING! For normal operation the “Service pin” menu information should not be changed. Contact your dealer for more information.

**Service PIN**

Allows you to enter a password to access the advanced options such as RDM PID, Set IP, Set Device IP, Set LED BIN and Change to bin (pwd: 50).

- ◆ Access the menu by pressing the “Mode Esc” key.
- ◆ Use the up/down arrow keys to reach the “OPTION” menu and press “Enter.” Finally, use the left/right arrow keys to select “Service Pin.”
- ◆ Scroll up to “50” using the left/right arrows and press “Enter” to confirm.

**Set IP**

Allows you to set the fixture’s IP address.

- ◆ Access the menu by pressing the “Mode Esc” key.
- ◆ Use the up/down arrow keys to access the “OPTION” menu and press “Enter.” Then use the left/right arrow keys to select “Service Pin.” Finally, use the left/right arrow keys to select “Set IP.”
- ◆ Use the up/down arrow keys to change the value and left/right to move from one number to the next. Press “Enter” to confirm.

**RDM PID**

Allows you to set the fixture’s RDM PID code.

- ◆ Access the menu by pressing the “Mode Esc” key.
- ◆ Use the up/down arrow keys to access the “OPTION” menu and press “Enter.” Then use the left/right arrow keys to select “Service Pin.” Finally, use the left/right arrow keys to select “RDM PID.”
- ◆ Use the up/down arrow keys to change the value and left/right to move from one number to the next. Press “Enter” to confirm.

**Set Device ID**

Allows you to set the fixture’s identifier.

- ◆ Access the menu by pressing the “Mode Esc” key.
- ◆ Use the up/down arrow keys to access the “OPTION” menu and press “Enter.” Then use the left/right arrow keys to select “Service Pin.” Finally, use the left/right arrow keys to select “Set Device ID.”
- ◆ Use the up/down arrow keys to change the value and left/right to move from one number to the next. Press “Enter” to confirm.

**FAN CONTROL****Head Control**

Allows you to choose the fan speed on the fixture head. The options are AUTO, STAGE or STUDIO.

- ◆ Access the menu by pressing the “Mode Esc” key.
- ◆ Use the up/down arrow keys to reach the “OPTION” menu and press “Enter.” Then use the left/right arrow keys to select “Fans Control.”
- ◆ Use the left/right arrow keys to select the fan option. Press “Enter” to confirm.

**DISP.SETTING****Shut off Time**

Allows the fixture’s LCD display to be turned off after a period of 2 to 59 minutes.

- ◆ Access the menu by pressing the “Mode Esc” key.
- ◆ Use the up/down arrow keys to reach the “OPTION” menu and press “Enter.” Then use the left/right arrow keys to select “Disp.Setting.” Finally, use the left/right arrow keys to select “Shut off Time.”
- ◆ Use the left/right arrow keys to change the value displayed. Press “Enter” to confirm.

**Flip Display**

Allows you to rotate the display by 180°. This can be highly useful when the fixture is installed with the head facing down.

- ◆ Access the menu by pressing the “Mode Esc” key.
- ◆ Use the up/down arrow keys to reach the “OPTION” menu and press “Enter.” Then use the left/right arrow keys to select “Disp. Setting.” Finally, use the left/right arrow keys to select “Flip Display.”
- ◆ Use the left/right arrow keys to select ON or OFF. Press “Enter” to confirm.

**Key Lock**

Activates the automatic keypad lock. If this function is enabled, the keys will be automatically locked 15 seconds after exiting edit mode. Hold the MENU key down for 3 seconds to deactivate this function.

- ◆ “Mode Esc” key.
- ◆ Use the up/down arrow keys to reach the “OPTION” menu and press “Enter.” Then use the left/right arrow keys to select “Disp. Setting.” Finally, use the left/right arrow keys to select “Key Lock.”
- ◆ Use the left/right arrow keys to select ON or OFF. Press “Enter” to confirm.

**DispFlash**

Causes the display to flash as a warning that there is no DMX signal.

- ◆ Access the menu by pressing the “Mode Esc” key.
- ◆ Use the up/down arrow keys to reach the “OPTION” menu and press “Enter.” Then use the left/right arrow keys to access the “Disp. Setting” submenu. Finally, use the left/right arrow keys to select “DispFlash.”
- ◆ Use the left/right arrow keys to select ON or OFF. Press “Enter” to confirm.

**SIGNAL SELECT****Signal Select**

This menu allows you to choose what type of signal is used to control the fixture (DMX, Art-Net, sACN or WDMX)..

- ◆ Access the menu by pressing the “Mode Esc” key.
- ◆ Use the up/down arrow keys to reach the “OPTION” menu and press “Enter.” Then use the left/right arrow keys to select “Signal Select” submenu.
- ◆ Use the left/right arrow keys to select the signal type used. Press “Enter” to confirm.

## SET UNIVERSE

### Set Universe

- ◆ Access the menu by pressing the “Mode Esc” key.
- ◆ Use the up/down arrow keys to reach the “OPTION” menu and press “Enter.” Then use the left/right arrow keys to select “Set Universe” submenu.
- ◆ Use the up/down arrow keys to scroll through until you locate the desired address and press “Enter” to confirm.

## TEMP. C/F

Allows you to select the unit of measurement for the temperature values, in either Celsius or Fahrenheit.

- ◆ Access the menu by pressing the “Mode Esc” key.
- ◆ Use the up/down arrow keys to reach the “OPTION” menu and press “Enter.” Then use the left/right arrow keys to access the “Temp. C/F” submenu.
- ◆ Use the left/right arrow keys to select the unit of measurement. Press “Enter” to confirm.

## INITIAL POS.

Controls the initial position of the fixture’s effects.

- ◆ Access the menu by pressing the “Mode Esc” key.
- ◆ Use the up/down arrow keys to reach the “OPTION” menu and press “Enter.” Then use the left/right arrow keys to access the “Initial Pos” submenu.
- ◆ Use the left/right arrow keys to select the desired setting, press “Enter”, and use the left/right arrow keys to change the value. Press “Enter” to confirm.

## WIRELESS DMX

This menu allows you to “reset” wireless pairing.

- ◆ Access the menu by pressing the “Mode Esc” key.
- ◆ Use the up/down arrow keys to reach the “OPTION” menu and press “Enter.” Then use the left/right arrow keys to access the “Wireless DMX” submenu.
- ◆ Use the left/right arrow keys to activate the setting. Press “Enter” to confirm.

## TRIGGER

### DMX Value Disp.

Allows you to view the DMX value received for each setting. The “ALL” option will display only the setting being edited.

- ◆ Access the menu by pressing the “Mode Esc” key.
- ◆ Use the up/down arrow keys to reach the “OPTION” menu and press “Enter.” Then use the left/right arrow keys to access the “Trigger” submenu. Use the right/left arrow keys to select “DMX value Disp.”
- ◆ Use the left/right arrow keys to select which setting to display. Press “Enter” to confirm.

### Set To Slave

Sets the fixture to SLAVE Mode for receiving instructions from a master luminaire (see Master/Save mode settings, below).

- ◆ Access the menu by pressing the “Mode Esc” key.
- ◆ Use the up/down arrow keys to reach the “OPTION” menu and press “Enter.” Then use the left/right arrow keys to access the “Trigger” submenu. Use the right/left arrow keys to select “Set To Slave.”
- ◆ Use the right/left arrow keys to define whether the fixture is Slave 1, Slave 2 or Slave 3, accordingly. Press “Enter” to confirm.

### Auto Program

Allows you to run an internal program (a sequence of scenes) by selecting whether the fixture is operating alone or as a master.

- ◆ Access the menu by pressing the “Mode Esc” key.

- ◆ Use the up/down arrow keys to reach the “OPTION” menu and press “Enter.” Then use the left/right arrow keys to access the “Trigger” submenu. Use the right/left arrow keys to select “Auto Program.”
- ◆ Use the right/left arrow keys to select whether the fixture is “Alone” or “Master.” Press “Enter” to confirm.

Note: See “AUTO” menu to create internal programs.

## RESETDEFAULT

Restores the factory default settings on the fixture.

- ◆ Access the menu by pressing the “Mode Esc” key.
- ◆ Use the up/down arrow keys to reach the “OPTION” menu and press “Enter.” Then use the left/right arrow keys to access the “ResetDefault” submenu.
- ◆ Use the right/left arrow keys to select ON to perform a reset to defaults. Press “Enter” to confirm.

## INFO

### TIME INFO.

#### Current Time

Shows the number of hours the fixture has been operating since it was powered on.

- ◆ Access the menu by pressing the “Mode Esc” key.
- ◆ Use the up/down arrow keys to reach the “INFO” menu and press “Enter.” Then use the left/right arrow keys to access the “Time Info” submenu.
- ◆ Use the left/right arrow keys to select “Current Time”, and press “Enter” to display the value.

#### Ttl Life Hrs

Shows the fixture’s total number of hours of operation.

- ◆ Access the menu by pressing the “Mode Esc” key.
- ◆ Use the up/down arrow keys to reach the “INFO” menu and press “enter.” Then use the left/right arrow keys to access the access the “Time Info” submenu.
- ◆ Use the left/right arrow keys to select “Ttl Life Hrs”, and press “Enter” to display the value.

#### Last Run Hrs

Shows the fixture’s length of operation since the last time this counter was reset.

- ◆ Access the menu by pressing the “Mode Esc” key.
- ◆ Use the up/down arrow keys to reach the “INFO” menu and press “Enter.” Then use the left/right arrow keys to access the access the “Time Info” submenu.
- ◆ Use the left/right arrow keys to select “Ttl Life Hrs”, and press “Enter” to display the value.

#### Timer PIN

The “Timer PIN” is the password required to reset the counter for “Last Run Hrs.” The PWD is 038.

- ◆ Access the menu by pressing the “Mode Esc” key.
- ◆ Use the up/down arrow keys to reach the “INFO” menu and press “Enter.” Then use the left/right arrow keys to select “Time Info.” Finally, use the left/right arrow keys to select “Timer PIN.”
- ◆ Scroll through using the left/right arrows until 038 appears and press “Enter” to confirm.

#### CLR LAST RUN

After entering the “Timer PIN”, you can reset the value for “Last Run Hrs” through this menu.

- ◆ Access the menu by pressing the “Mode Esc” key.

- ◆ Use the up/down arrow keys to reach the “INFO” menu and press “Enter.” Then use the left/right arrow keys to access “Clr Last Run” submenu.
- ◆ Use the left/right arrow keys to select “ON” to validate the reset.

#### TEMP. INFO

##### Head Temp.

Shows the current temperature of the fixture head.

- ◆ Access the menu by pressing the “Mode Esc” key.
- ◆ Use the up/down arrow keys to reach the “INFO” menu and press “Enter.” Then use the left/right arrow keys to access the “Temp.Info” submenu.
- ◆ Press “Enter” once again to display the temperature of the head.

#### SOFTWARE VER

Displays the software version of the fixture.

- ◆ Access the menu by pressing the “Mode Esc” key.
- ◆ Use the up/down arrow keys to reach the “INFO” menu and press “Enter.” Then use the left/right arrow keys to access the “Software ver” submenu.
- ◆ Press “Enter” once again to display the software version.

#### NETWORK

This menu directly displays the following network information for the fixture: IP address, subnet mask and MAC address

- ◆ Access the menu by pressing the “Mode Esc” key.
- ◆ Use the up/down arrow keys to reach the “INFO” menu and press “Enter.” Then use the left/right arrow keys to access the “Network” submenu.
- ◆ Press “Enter” once again to display the information.

#### TEST

##### HOME

Allows you to reset the functions from a DMX controller. You can select these functions by adjusting the channel.

- ◆ Access the menu by pressing the “Mode Esc” key.
- ◆ Use the up/down arrow keys to reach the “TEST” menu and press “Enter.” Then use the left/right arrow keys to access the “Home” submenu.
- ◆ Press “Enter” once again to select “All” or “Pan&Tilt”.

##### TEST CHANNEL

Tests each of the fixture’s settings (e.g., PAN, TILT).

- ◆ Access the menu by pressing the “Mode Esc” key.
- ◆ Use the up/down arrow keys to reach the “TEST” menu and press “Enter.” Then use the left/right arrow keys to access the “Test Channel” submenu.
- ◆ The fixture then runs in test position. Use the left/right arrow keys to scroll through and test each setting.

##### MANUAL CTRL.

Allows you to access all the fixture’s settings manually (e.g., PAN, TILT). The shutter and the electronic dimmer are by default 100% open.

- ◆ Access the menu by pressing the “Mode Esc” key.
- ◆ Use the up/down arrow keys to reach the “TEST” menu and press “Enter.” Then use the left/right arrow keys to access the “Manual Ctrl” submenu.
- ◆ Use the left/right arrow keys to scroll through and check each setting.

#### CALIBRATION

Calibrates certain settings such as Pan, Tilt and Zoom. The password required to access the calibration function is 050.

- ◆ Access the menu by pressing the “Mode Esc” key.
- ◆ Use the up/down arrow keys to reach the “TEST” menu and press “Enter.” Then use the left/right arrow keys to access the “Calibration” submenu.
- ◆ Press “Enter” once again to access the password (050), and press “Enter” to confirm.
- ◆ Use the left/right arrow keys to move from one setting to another and press “Enter” to access the calibration function of the setting. Finally, press “Enter” to confirm the change.

#### PRESET

##### SELECT PROG.

Allows you to select the program for “Program Run.”

##### EDIT PROG.

Allows you to edit internal programs.

##### EDIT SCENES

Allows you to edit scenes within the internal programs.

#### SCENES INPUT

The luminaire features a DMX recorder, which can receive the scenes programmed on your DMX controller. Set the desired number of scenes from the control panel. Then run the scenes from your controller. They will be automatically transmitted to the COSMOPIX-R.

## MASTER/SLAVE MODE SETTINGS

A MASTER fixture can send up to 3 different sets of data to a SLAVE fixture (e.g., a MASTER fixture can control 3 different SLAVE fixtures which will each perform 3 different programs). The MASTER fixture sends the 3 programs in a continuous loop.

The SLAVE fixture receives data from the MASTER fixture according to the group to which the SLAVE fixture is assigned. For example, if the SLAVE fixture has been assigned to “Slave 1” in the menu “Set to Slave”, the MASTER fixture sends “Auto Program Part 1” to this SLAVE fixture. If it was assigned to “Slave 2”, the SLAVE fixture would receive the program “Auto Program Part 2” from the MASTER fixture.

To launch a program, follow this procedure:

##### 1. Slave Settings - SLAVE fixture adjustment

Use the buttons to select “Function Mode.”

Press ENTER to confirm.

Use the buttons to select “Set slave to.”

Press ENTER to confirm.

Use the buttons to select “Slave 1”, “Slave 2” or “Slave 3.”

Press ENTER to confirm.

Press MODE/ESC to return to the main menu.

##### 2. Automatic Program Run

Use the buttons to select “Function Mode.”

Press ENTER to confirm.

Use the buttons to select "Auto Program."  
 Press ENTER to confirm.  
 Use the buttons to select "Master" or "Alone." "Master" sets the fixture as the master.  
 Press ENTER to confirm.  
 Press MODE/ESC to return to the main menu.

3. Program selection for Auto Pro Part  
 Use the buttons to select "Edit program."  
 Press ENTER to confirm.  
 Use the buttons to select "Select programs."  
 Press ENTER to confirm.  
 Select "Auto Program Part 1", "Auto Program Part 2" or "Auto Program Part 3", for the Slave program to be sent. Selecting "Part 1" will cause the SLAVE to run the same program as the MASTER fixture.  
 Press ENTER to confirm.  
 Press MODE/ESC to return to the main menu.

4. Program selection for Edit Program  
 Use the buttons to select "Edit program."  
 Press ENTER to confirm.  
 Use the buttons to select "Edit program."  
 Press ENTER to confirm.  
 Use the buttons to select the desired program.  
 You can edit specific scenes in a given program.  
 Press ENTER to confirm.  
 Press MODE/ESC to return to the main menu.

5. Automatic Scene Recording  
 Use the buttons to select "Edit program."  
 Press ENTER to confirm.  
 Use the buttons to select "Edit scenes."  
 Use the buttons to select the number of desired scenes. (maximum amount: 250 scenes)  
 Press ENTER to confirm.  
 Press MODE/ESC to return to the main menu.

Example:  
 "Program 2" includes scenes: 10, 11, 12, 13.  
 "Program 4" includes scenes: 8, 9, 10.  
 "Program 6" includes scenes: 12, 13, 14, 15.  
 "Auto Program Part 1" is "Program 2."  
 "Auto Program Part 2" is "Program 3."  
 "Auto Program Part 3" is "Program 6."

The 3 groups of SLAVE fixtures run the "Auto Program" function in the following sequence:

Part 1:

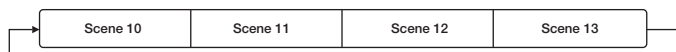

Part 2:

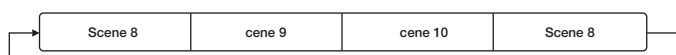

Part 3:

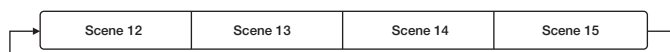

### LED MAPPING

The diagram shows the order of the LED addresses from a front view of the luminaire and control panel, from left to right.

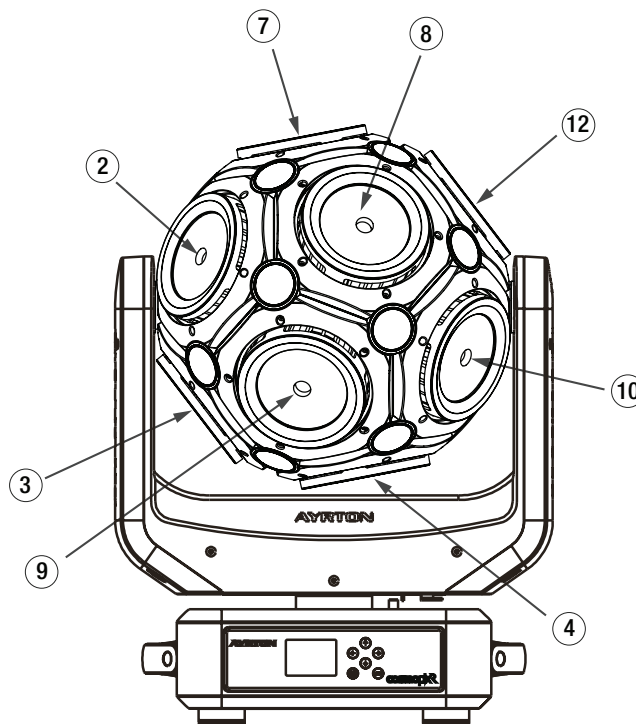
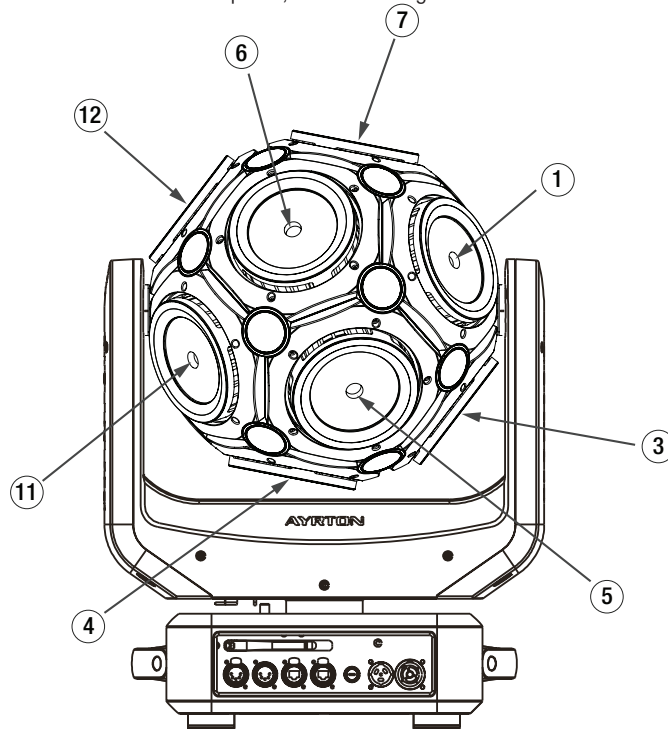

### DMX CHART

THE following chart shows the functions and corresponding values for each DMX channel according to mode whether Standard (St), Basic (Ba) or Extended (Ex):

COSMOPIX-R (18 - 20 - 64 channels)				
Mode/Channel			Value	Function
St	Ba	Ex		
1	1	1		<b>PAN Movement 8bit :</b>
			0-255	Pan Movement
2		2		<b>Pan Fine 16bit</b>
			0-255	Fine control of Pan movement
3	2	3		<b>TILT Movement 8bit :</b>
			0-255	Tilt Movement
4		4		<b>Tilt Fine 16bit</b>
			0-255	Fine control of Tilt movement
5	3	5		<b>Speed Pan/Tilt movement:</b>
			0-225	max to min speed
			226-235	blackout by movement
6	4	6	236-235	no function
				<b>Pan Motor continuous rotation :</b>
			0-127	No function
			128-189	Forwards Pan rotation from fast to slow
7	5	7	190-193	No rotation
			194-255	Backwards Pan from slow to fast
				<b>Tilt Motor continuous rotation :</b>
			0-127	no function
8	6	8	128-189	Forwards Tilt rotation from fast to slow
			190-193	No rotation
			194-255	Backwards Tilt rotation from slow to fast
				<b>Red LED - All arrays</b>
9	7	9	0-255	Red ( 0-Black , 255-100% Red )
				<b>Green LED - All arrays</b>
10	8	10	0-255	Green ( 0-Black , 255-100% Green )
				<b>Blue LED - All arrays</b>
11	9	11	0-255	Blue ( 0-Black , 255-100% Blue )
				<b>White LED - All arrays</b>
		17	0-255	White ( 0-Black , 255-100% White )
				<b>Red LED - array 1</b>
		18	0-255	Red ( 0-Black , 255-100% Red )
				<b>Green LED - array 1</b>
		19	0-255	Green ( 0-Black , 255-100% Green )
				<b>Blue LED - array 1</b>
		20	0-255	Blue ( 0-Black , 255-100% Blue )
				<b>White LED - array 1</b>
		21	0-255	White ( 0-Black , 255-100% White )
				<b>Red LED - array 2</b>
		22	0-255	Red ( 0-Black , 255-100% Red )
				<b>Green LED - array 2</b>
		23	0-255	Green ( 0-Black , 255-100% Green )
				<b>Blue LED - array 2</b>
		24	0-255	Blue ( 0-Black , 255-100% Blue )
				<b>White LED - array 2</b>
.....	.....	.....	.....	.....
		61	0-255	White ( 0-Black , 255-100% White )
				<b>Red LED - array 12</b>
		62	0-255	Red ( 0-Black , 255-100% Red )
				<b>Green LED - array 12</b>
			0-255	Green ( 0-Black , 255-100% Green )

COSMOPIX-R (18 - 20 - 64 channels)				
Mode/Channel			Value	Function
St	Ba	Ex		
		63		<b>Blue LED - array 12</b>
			0-255	Blue ( 0-Black , 255-100% Blue )
		64		<b>White LED - array 12</b>
			0-255	White ( 0-Black , 255-100% White )
12	10	8		<b>Shutter, strobe:</b>
			0-31	Led turn off
			32-63	Led turn on
			64-95	Strobe effect slow to fast
			96-127	Led turn on
			128-159	Pulse-effect in sequences
			160-191	Led turn on
			192-223	Random strobe effect slow to fast
13	11	9		<b>Dimmer intensity:</b>
			0-255	Intensity 0 to 100%
14	12	10		<b>Color Macro:</b>
			0-7	No function
			8-39	from RED to YELLOW
			40-71	from YELLOW to GREEN
			72-103	from GREEN to CYAN
			104-135	from CYAN to BLUE
			136-167	from BLUE to MAGENTA
			168-199	from MAGENTA to RED
			200-231	from RED to WHITE
			232-255	Crossfading colours from slow to fast
15	13	11		<b>Color Presets:</b>
			0-4	No function
			5-9	White 2700K
			10-14	White 3200K
			15-19	White 4300K
			20-24	White 5600K
			25-29	White 6500K
			30-34	White 8000K
			35-39	Yellow
			40-44	Magenta
			45-49	Cyan
			50-54	Salmon
			55-59	Turquoise
			60-64	Light Green
			65-69	Steel Blue
			70-74	Orange
			75-79	Straw
			80-84	Pale Lavander
85-89	Pink			
90-94	Red			
95-99	Green			
100-104	Blue			
105-109	White			
110-114	Rainbow 1			
115-119	Rainbow 2			
120-124	Rainbow 3			
125-255	Reserved			
19	17	15		<b>Color Presets Dimmer:</b>
			0-255	Dimmer 100 to 0%

COSMOPIX-R (18 - 20 - 64 channels)				
Mode/Channel			Value	Function
St	Ba	Ex		
16	14	12		<b>Chase Patterns</b>
			0-9	LED turn Off
			10-11	Chase 1
			12-13	Chase 2
			14-15	Chase 3
			16-17	Chase 4
			18-19	Chase 5
			20-21	Chase 6
			22-23	Chase 7
			24-25	<b>Chase 8</b>
			26-27	Chase 9
			28-29	<b>Chase 10</b>
			30-31	Chase 11
			32-33	Chase 12
			34-35	Chase 13
			36-37	Chase 14
			38-39	Chase 15
			40-41	Chase 16
			42-43	Chase 17
			44-45	Chase 18
			46-47	Chase 19
			48-49	Chase 20
			50-51	Chase 21
			52-53	Chase 22
			54-55	Chase 23
			56-57	Chase 24
			58-59	Chase 25
			60-61	Chase 26
			62-63	<b>Chase 27</b>
			64-65	Chase 28
			66-67	Chase 29
			68-69	Chase 30
			70-71	<b>Chase 31</b>
			72-73	Chase 32
			74-75	<b>Chase 33</b>
			76-77	Chase 34
			78-79	Chase 35
			80-81	Chase 36
			82-83	Chase 37
			84-85	Chase 38
			86-87	Chase 39
			88-89	Chase 40
			90-91	Chase 41
			92-93	Chase 42
			94-95	Chase 43
			96-97	Chase 44
			98-99	Chase 45
			100-101	Chase 46
			102-103	Chase 47
			104-105	Chase 48
			106-107	Chase 49
			108-109	Chase 50
			110-111	Chase 51
			112-113	Chase 52
			114-115	Chase 53
			116-117	Chase 54
			118-119	Chase 55
			120-121	Chase 56
122-123	Chase 57			
124-125	Chase 58			

COSMOPIX-R (18 - 20 - 64 channels)				
Mode/Channel			Value	Function
St	Ba	Ex		
16	14	12	126-127	<b>Chase 59</b>
			128-129	Chase 60
			130-131	Chase 61
			132-133	Chase 62
			134-135	Chase 63
			136-137	Chase 64
			138-139	Chase 65
			140-141	Chase 66
			142-143	Chase 67
			144-145	<b>Chase 68</b>
			146-147	Chase 69
			148-149	<b>Chase 70</b>
			150-151	Chase 71
			152-153	Chase 72
			154-155	Chase 73
			156-157	Chase 74
			158-159	Chase 75
			160-161	Chase 76
			162-163	Chase 77
			164-165	Chase 78
			166-167	Chase 79
			168-169	Chase 80
			170-171	Chase 81
			172-173	Chase 82
			174-175	Chase 83
			176-177	Chase 84
			178-179	Chase 85
			180-181	Chase 86
			182-183	<b>Chase 87</b>
			184-185	Chase 88
			186-187	Chase 89
			188-189	Chase 90
			190-191	<b>Chase 91</b>
			192-193	Chase 92
			194-195	<b>Chase 93</b>
			196-197	Chase 94
			198-199	Chase 95
			200-201	Chase 96
			202-203	Chase 97
			204-205	Chase 98
			206-207	Chase 99
208-209	Chase 100			
210-211	Chase 101			
212-213	Chase 102			
214-215	Chase 103			
216-217	Chase 104			
218-219	Chase 105			
220-221	Chase 106			
222-223	Chase 107			
224-225	Chase 108			
226-227	Chase 109			
228-229	Chase 110			
230-255	Reserved			
17	15	13		<b>Chase Speed</b>
			0-125	Fast to Slow Backward
			126-130	Stop (Speed=0)
			131-255	Slow to Fast Forward
18	16	14		<b>Chase Fade</b>
			0-255	Fade Chase

COSMOPIX-R (18 - 20 - 64 channels)				
Mode/Channel			Value	Function
St	Ba	Ex		
20	18	16		<b>Reset, internal programs:</b>
			0-79	Normal
			80-84	All motor reset
			85-87	Scan motor reset
			88-90	no function
			91-93	no function
			94-96	no function
			97-99	no function
			100-119	Internal program 1 (scene 1~8 of EEPROM)
			120-139	<b>Internal program 2 (scene 9~16 of EEPROM)</b>
			140-159	Internal program 3 (scene 17~24 of EEPROM)
			160-179	<b>Internal program 4 (scene 25~32 of EEPROM)</b>
			180-199	Internal program 5 (scene 33~40 of EEPROM)
			200-219	Internal program 6 (scene 41~48 of EEPROM)
			220-239	Internal program 7 (scene 49~56 of EEPROM)
			240-255	Internal program 8 (scene 57~64 of EEPROM)

## ERROR MESSAGES

### ERROR MESSAGES

When you turn on the COSMOPIX-R, it will first perform an automatic reset. The display may show “Err channel is XX” indicating there is a problem with one or more of the channels. “XX” represents channel 1, 2, 3, 4, 5 or 6, which contain the testing sensor for positioning. For example, the message, “Err channel is Red LED -all arrays”, indicates an error in channel 1. If there is an error on channel 1 and channel 3 at the same time, the following error message may appear: “Err channel is Pan movement”, “Err channel is Tilt movement”. The system will flash twice, and the fixture will generate a second reset. If the error message persists after more than two resets, the channels showing errors will not work properly but the other channels will function normally.

Please contact your authorized dealer or manufacturer for service and do not attempt to repair the luminaire yourself

#### PAN- MOVEMENT ER

(PAN-yoke movement error): This message will appear after the reset if the yoke’s magnetic-indexing circuit malfunctions (failed sensor or magnet missing) or the stepping-motor is defective (also caused by its driving IC on the main PCB). The PAN- movement does not return to the default position after the reset.

#### TILT- MOVEMENT ER

(TILT-head movement error): This message will appear after the reset if the head’s magnetic-indexing circuit malfunctions (sensor failed or magnet missing) or the stepping-motor is defective (also caused by its driving IC on the main PCB). The TILT- movement does not return to the default position after the reset.

## CARE AND MAINTENANCE

The care and maintenance of your COSMOPIX-R should be ensured by a qualified technician. Your COSMOPIX-R requires regular servicing.

The frequency depends essentially on its operating conditions and environment. Intensive use in a dusty environment, or a lack of ventilation around the fixture, may disrupt operation, result in overheating and cause damage that is not covered by the warranty.

### **WARNING!**

*Disconnect from mains before servicing.*

### **UPDATING THE LUMINAIRE**

Ayrton is continually upgrading this product line. It is therefore possible that a new software version is available that will increase the unit’s capabilities.

Updates are performed using Ayrton’s update box. Contact your dealer for more information.

To display the version of your device, go into the “Info” menu and select “Software version” (see options details under the “INFO” menu). It is advisable to use the same software version for multiple fixtures.

### **CLEANING**

Your COSMOPIX-R requires cleaning at regular intervals. Be aware that accumulated dust and residue on the air vents, body and glass of the fixture may reduce efficiency and impair proper operation.

Before cleaning, disconnect the power cable from source.

Use compressed air to blow away dust particles accumulated on and between the cooling fins at the rear of the luminaire’s optical system.

Clean the glass of the fixture with a slightly damp soft cloth. When necessary, use a non-alcohol-based glass cleaner. Never use harsh solvents!

### **WARNING!**

*Never use alcohol or any chemical agent to clean the optical system of an Ayrton product.*

### **COMPLIANCE CHECK**

Your installation should be checked regularly by certified service center. In addition, the following should be checked once a year by a qualified technician:

- The fixture’s attachment system must be correctly installed and show no sign of corrosion.
- The fixture’s mounting bracket should not be distorted in any way or show any trace of corrosion.
- The safety cable should be attached at the appropriate spot.
- Mechanical parts should show no sign of wear.
- The electrical cables should show no sign of wear, cuts or splices.



## TECHNICAL SPECIFICATIONS

### OPTICAL

- Optical efficiency: 85%
- Opening angle of the beam: 4,5°

### LIGHT SOURCE

- 12 high-power multicolor 60-Watt LED emitters
- Brightness: up to 18000 lumens
- Estimated lifespan of LED emitters: 50,000 hours
- Guaranteed “no-flicker” effect perfectly suited for television applications and all video recorded events

### COLORS

- System of 4-color mixing (red, green, blue and white) ensuring a high color-rendering index (CRI)
- Uniformly produced light, without shadows, and offering rich saturated shades and pastel hues in 4.29 billion colors (8-bit resolution).
- Virtual color wheel including white light presets
- Fixed colors and reprogrammable dynamic color change

### DIMMER, STROBE

- Electronic dimmer for light adjustment from 0 to 100% without color change (16-bit)
- High-speed strobe effect in white or color at 1 to 18 flashes/second
- Pre-programmed variable strobe effects

### SOFTWARE FEATURES

- Full menus for setting DMX address and advanced functions
- Compatible with the DMX/RDM (Remote Device Management) protocol
- Pre-programmed macro modes
- Information menu including: timer, temperature, software version, etc.

### CONTROL

- USITT DMX512
- Automatic features for managing your luminaire without a DMX console
- DMX RDM-compatible
- Integrated control panel with LCD display and 6 buttons
- DMX512 input/output
- Choice of 3 DMX modes (from 18 to 64 channels)
- Wireless System: LumenRadio wireless CRMX RDM receiver

### POWER SUPPLY

- Electronic power distribution with Power Factor Correction (PFC) from 110-240 VAC, 50/60 Hz
- 700 Watt maximum power
- Power supply via powerCON TRUE1 connector
- Supplied AC power cable

### COOLING

- Advanced forced-air cooling system
- Self-adjusting fan for reduced noise level (in AUTO mode)
- User-selectable air-cooling modes

### CONSTRUCTION

- Covers: molded PC-ABS thermoplastic, class V0 (fire retardant)
- Chassis: steel plates and aluminum
- 2 handles for transport
- Protection rating: IP20 (indoor use only)
- Finish: Carbon black

### INSTALLATION

- 2 OMEGA bracket with quarter-turn locks included
- Safety cable attachment

### OPERATING PARAMETERS

- Operating positions: all (on floor or attached to a support)
- Maximum authorized ambient temperature (Ta Max): 45°C (113°F)
- Minimum authorized ambient temperature (Ta Min): -10°C (14°F)
- Minimum projection distance: 0.2 m (8 inches)

### DIMENSIONS

- Product: 427 mm x 585 mm x 352 mm (L x H x D)
- Protective foam: 488 mm x 602 mm x 421 mm (L x H x D)

### WEIGHT

- Product: 25,1 kg
- Product in packaging with accessories: 32 kg

### PRODUCT CODE

- 015750: COSMOPIX-R AUTOMATED LUMINAIRE

### FOAM FOR FLIGHT CASE

COSMOPIX-R is delivered in a carton packed with a dense, protective foam surrounding the fixture. This reusable protective shell is intended for a flight case that can be custom built for the luminaire.

AYRTON does not offer custom flight cases for the COSMOPIX-R. This accessory is to be provided by the user.

The main dimensions of the protective shell appear in the following diagram:

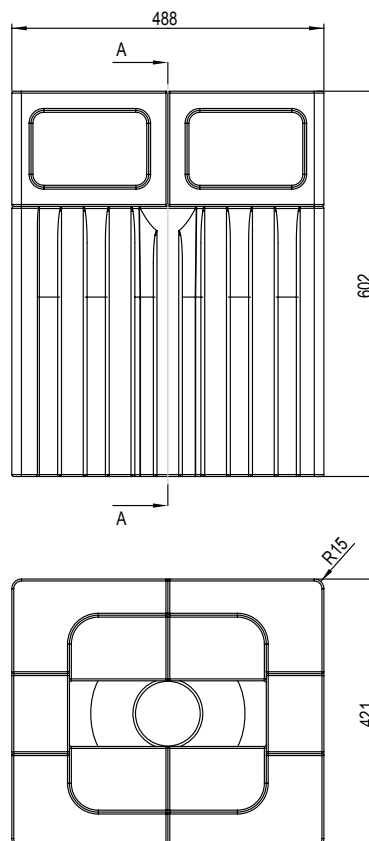

## WARRANTY

The AYRTON COSMOPIX-R fixture is guaranteed against manufacturing defects for the duration of one (1) year from the date of purchase.

This warranty does not cover the unit for evidence of physical shock or damage caused by abuse or any use not in accordance with the operating conditions set forth in the present user manual.

In addition, cosmetic defects caused by the normal wear and tear of the unit are not covered under the warranty.

Any modification to the fixture will void the warranty. AYRTON cannot under any circumstances be held liable for quality and conformity regarding the installation of this product, which is the responsibility of the installer.

Broken glass lenses on the COSMOPIX-R, and any damage that could arise thereof, are excluded from the warranty. Any possible cosmetic defects, provided you report them to your AYRTON dealer upon unpacking the device and before use, may be covered by the warranty.

**Note:**

The manufacturer is not responsible for any errors or omissions that may occur in this document. All information contained in this manual is subject to change without notice.





**AYRTON**

Digital Lighting